

THERMOWELLS

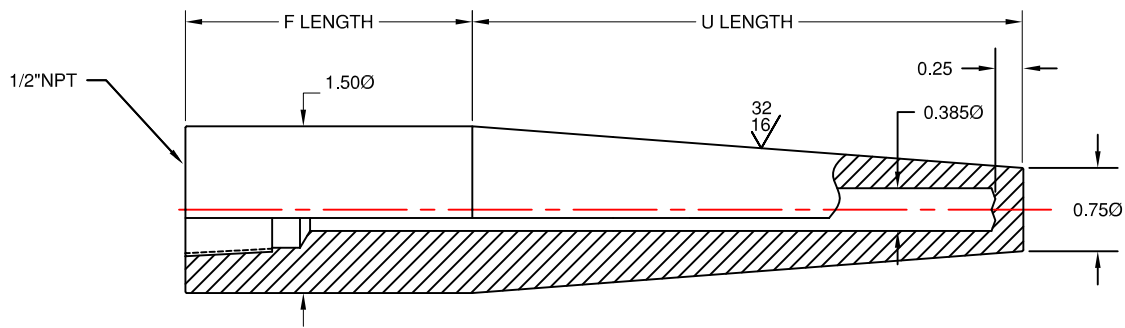

TYPE 03

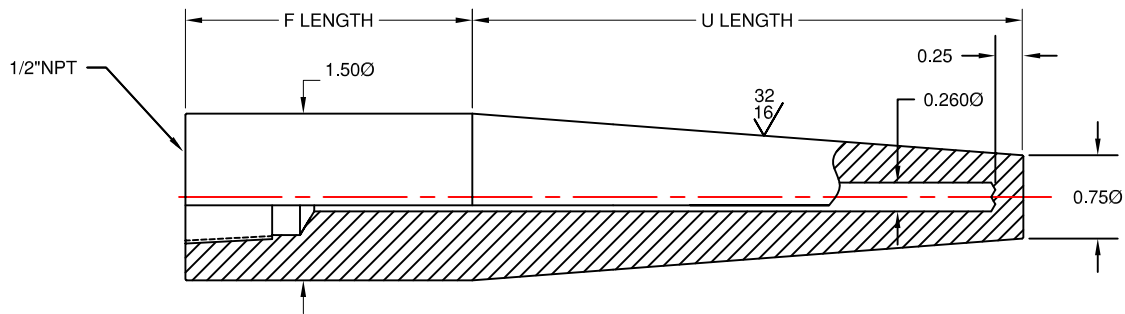

TYPE 031

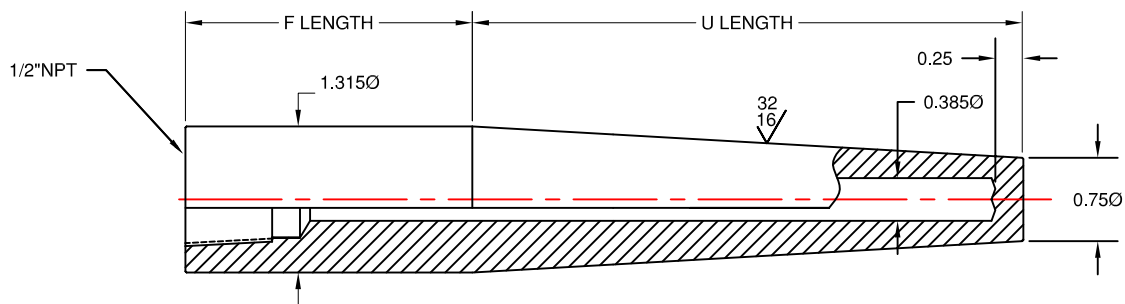

TYPE 04

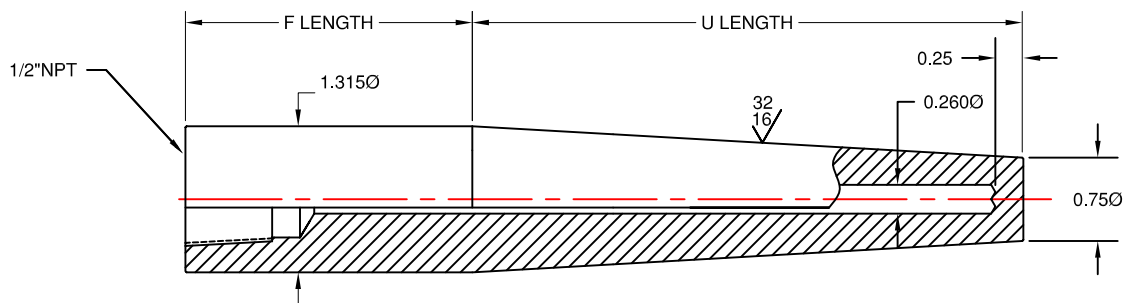

TYPE 041

STANDARD TOLERANCES

U LENGTH
 12" or Less ± 0.063
 12" or Over ± 0.13
 F LENGTH
 ± 0.25
 STEM DIAMETER
 ± 0.015
 BORE DIAMETER
 $+0.005/-0.003$
 END THICKNESS
 ± 0.063

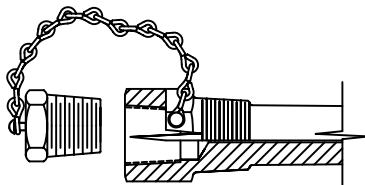

PLUG & CHAIN
 Prevent foreign matter from entering test wells when not in use. Plugs are available in Brass or Stainless Steel. A captive chain is attached to prevent loss.
 To order as a test well specify plug & chain code letters after well ordering code.

CODE	PLUG & CHAIN
-BPC	BRASS
-SSPC	STN. STL.

ORDERING CODE

